



# Elba OV

Oval Air Massage Bath



## Features

- 59-1/2" x 42" x 23" Oval air massage bath
- Three advanced therapy air bath systems — Choose the perfect hydrotherapy system for your lifestyle
- Deep bathing well
- Advanced multifunctional digital controller — Featuring on/off, variable speeds, wave, pulse, heated backrest and chromatherapy control (standard)
- MoodScape™ Chromatherapy system — Seven healing light settings with a full spectrum sequencing mode (standard)
- PerfectBack™ — Multiple soothing recessed back jets with on/off heated neck/back rest (standard)
- Heated SilentAir™ system — Quiet single/dual 1HP air blowers with sound suppressing mufflers and pump mounts (standard)
- QuickDrain™ channel system and automatic purge system offer the ultimate in hygiene — Ideal for luxury aromatherapy and bath additives (standard)
- Color-Match trim for air jets (standard) — Optional finishes include polished chrome, everbrass (PVD) and brushed nickel
- Cable drain with matching trim (standard) — Optional finishes available
- “Jellybean” pillow (standard)
- Available in Standard and Premium Colors (See Price Book for specific colors)
- Outstanding protection – Mansfield® Limited Ten Year Warranty

### HealthTouch™

Direct Therapy Air System

- Rigorous full body hydrotherapy massage with 43 powerful side/back air jets
- Features the proprietary QuickDrain™ channel system

### GentleTouch™

Immersion Air System

- Total relaxation with 54 air jets to immerse and envelop the bather from all sides
- Fully sealed air injector system, ideal for luxury bath additives and essential oils

### DualTherapy™

Complete Performance System

- The best of both worlds: HealthTouch™ and GentleTouch™ combined
- A full featured, dual blower system for the ultimate in hydrotherapy

Model No.	Description	Approx. Wt.
9085	59-1/2" x 42" x 23" Oval HealthTouch™ direct therapy air system. Specify color and options.	120 lbs. (55 kg)
9185	59-1/2" x 42" x 23" Oval GentleTouch™ immersion air system. Specify color and options.	120 lbs. (55 kg)
9285	59-1/2" x 42" x 23" Oval Dual Therapy™ complete performance system. Specify color and options.	135 lbs. (61 kg)
AR1200	Blower relocation kit	8 lbs. (1.8 kg)



# Elba OV

Oval Air Massage Bath



## Features & Options

Elba OV	Full Function Digital Controller	Wave / Pulse	Variable Speed	Air Jets / Injectors	SilentAir™ Heated Blowers	Remote Blower Location	Auto Purge System	PerfectBack™ Air Jet System	On/OFF Heated Back/Neck Rest	Dual Heated Backrest	Custom Design Pillow	MoodScape™ Chromatherapy	Ergonomic Handles	Trim Finish Selection	Remote Cable Drain	Nailing Flange	Removable Apron	ABS Drip Pan Base
HealthTouch™ Model 9085	STD	STD	STD	43 1 HP	Single	OPT	STD	STD	STD	N/A	N/A	STD	N/A	STD	STD	N/A	N/A	STD
GentleTouch™ Model 9185	STD	STD	STD	54 1 HP	Single	OPT	STD	STD	STD	N/A	N/A	STD	N/A	STD	STD	N/A	N/A	STD
DualTherapy™ Model 9285	STD	STD	STD	97 1 HP	Dual	OPT	STD	STD	STD	N/A	N/A	STD	N/A	STD	STD	N/A	N/A	STD

## Technical Information

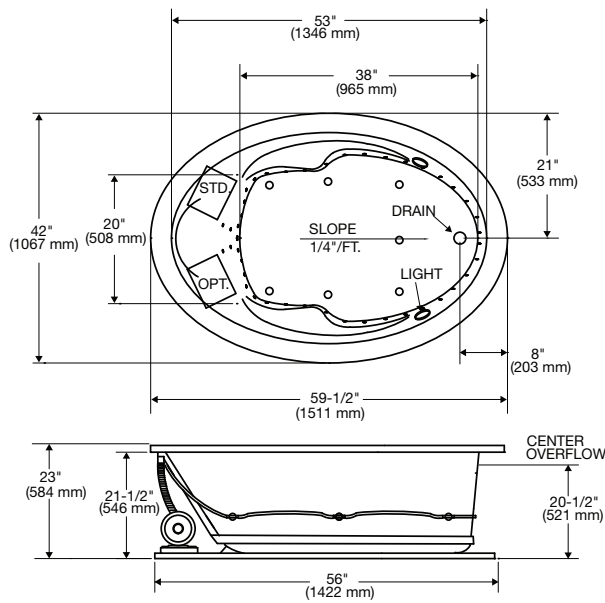

Note: Rough-in measurements may vary 1/4" (+/-)

No apron available on this model.

Blower locations are shown for clarity.  
STD - standard blower location.  
OPT - optional blower location.

Note: Install this product according to the installation guide.  
Fixture dimensions are nominal and conform to tolerances in ASME Standard A112.19.2

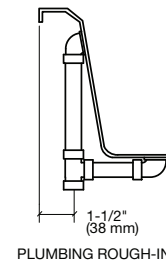
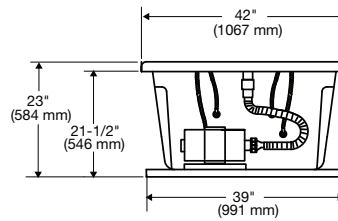

INSTALLER NOTE: DUE TO THE FREEFORM SHAPE OF THIS TUB IS RECOMMENDED THAT THE TUB BE ON THE JOBSITE BEFORE MAKING THE FINAL CUT OUT FOR DROP IN INSTALLATION.

## Specifications

Dimensions	59-1/2" x 42" x 23"	HealthTouch™ Model 9085	1 HP blower, 1 single phase, 120V, 60 HZ, premounted
Material	Acrylic, fiberglass reinforced	Electrical	120V, 20 AMP, GFCI
Construction	Self-contained, pre-plumbed air massage bath, mounted on a thermoformed base	Number of Air Jets	43 perimeter side/back air jets
Water Capacity	70 gal. max., 50 gal. min. (265 liters/189 liters)	GentleTouch™ Model 9185	1 HP blower, 1 single phase, 120V, 60 HZ, premounted
Floor Loading	47 lbs./sq. ft. (229 kg/m <sup>2</sup> )	Electrical	120V, 20 AMP, GFCI
Shipping Weight	155 lbs. (71 kg)	Number of Air Jets	54 body/foot micro air jets (9 injectors) with 12 side/back air jets
Shipping Weight	165 lbs. (75 kg)	DualTherapy™ Model 9285	Two 1 HP blower, 1 single phase, 120V, 60 HZ, premounted
Warranty	Limited Ten Year	Electrical	Two 120V, 20 AMP, GFCI
		Number of Air Jets	43 perimeter side/back air jets 54 body/foot micro air jets (9 injectors) with 12 side/back air jets

These dimensions are nominal and are subject to change without notice.  
When tested for compliance to the requirement of ANSI A112.19.7M and A112.19.8M for "Whirlpool Bath Appliances" and ANSI Z124 for "Plastic Bathtub Units" the tested units are found to comply and are acceptable for listing under the Terralab Engineers, Inc. follow-up service. Listed Number 15197.  
Certified for permanent electrical supply connection only.

