



Model 6123
Shown in White
with EverBrass (PVD)

FEATURES

- 35-1/2" x 71-1/4" x 23" Rectangular whirlpool
- Simple air-switch operation
- 1-1/4 HP single-speed pump
- Six powerful Ultra-Swirl jets
- Two air controls
- Integral apron and tile flange
- Optional removable oval access panel on apron
- Color-Match trim, metal upgrades available (Consult Price Book for specific colors)
- Available in White and Standard Colors (Consult Price Book for specific colors)
- Outstanding protection - Mansfield® Limited One Year Acrylic Warranty



Optional Removable Access Panel

Model No.	Description	Approx.Wt.
6123	35-1/2" x 71-1/4" x 23" Lefthand rectangular whirlpool TFS	130 lbs. (59 kg)
6122	35-1/2" x 71-1/4" x 23" Righthand rectangular whirlpool TFS Specify color and options when ordering.	
6623	35-1/2" x 71-1/4" x 23" Lefthand rectangular bath TFS	110 lbs. (50 kg)
6622	35-1/2" x 71-1/4" x 23" Righthand rectangular bath TFS Specify color and options when ordering.	
PF1340	Access panel	3 lbs. (1.3 kg)
SWP151	Factory installed In-Line heater	3 lbs. (1.3 kg)
PF1320	Chrome lift and turn drain kit	1 lbs. (.4 kg)
PF1321	Everbrass lift and turn drain kit	1 lbs. (.4 kg)
PF1335	Chrome trim upgrade	1 lbs. (.4 kg)
PF1336	Everbrass trim upgrade	1 lbs. (.4 kg)



For more information or to order, call 800-325-4422.
www.whirlpoolbathtubs.com

3672 TFS ALTO

Rectangular Whirlpool or Bath

PRO-FIT®

UPGRADES

Access Panel - 6 ft. Model

- This upgrade provides quick and easy access through removable apron to whirlpool pump and interior parts.



Lift & Turn Drain Kit Chrome and Everbrass (PVD)

- The lift and turn drain kit provides simple and easy draining of the bathtub.



Factory Installed In-line Heater

- A reliable, heating control upgrade maintains water temperature at desired level and operates when flow of water is detected in the system. Features a standard plug for easy electrical connection (GFCI: 120V, 20 amp dedicated circuit required to power this heater).



Trim Upgrade

- This option allows an upgrade to Chrome or Everbrass (PVD) trim including jets, intake, control and air control(s).

TECHNICAL INFORMATION

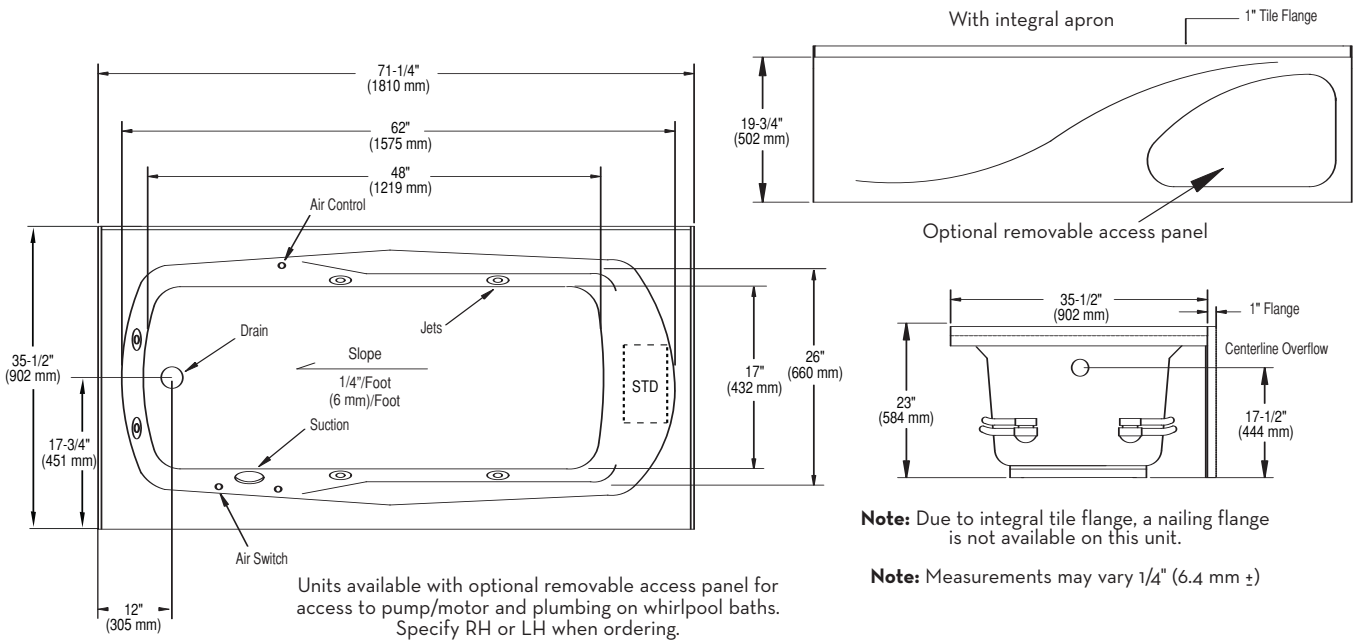

SPECIFICATIONS

Dimensions	35-1/2" x 71-1/4" x 23"	Number of Jets	Six
Material	Acrylic, fiberglass reinforced	Air Volume Control	Two
Construction	Self-contained, pre-plumbed whirlpool bath	Water Capacity	52 gal. max., 38 gal. min. (198 liters/144 liters)
Pump Motor	1-1/4 HP, 1 phase, 120 volt, 60 HZ, 5.9 AMP,	Floor Loading	47 lbs./sq. ft. (229 kg/m ²)
Electrical Requirements	120 volt, 20 AMP, GFCI	Shipping Weight	170 lbs. (77 kg)
		Warranty	Limited One Year

These dimensions are nominal and are subject to change without notice.
When tested for compliance to the requirement of ANSI A112.19.7M and A112.19.8M for "Whirlpool Bath Appliances" and ANSI Z124 for "Plastic Bathtub Units" the tested units are found to comply and are acceptable for listing under the Terralab Engineers, Inc. follow-up service. Listed Number 15197.
Certified for permanent electrical supply connection only.

Mansfield®
performance for a lifetime™