



Model 6024
Shown in White
with EverBrass (PVD trim)

FEATURES

- 42" x 60" x 20-1/4" Rectangular whirlpool
- Simple air-switch operation
- 1-1/4 HP single-speed pump
- Six powerful Ultra-Swirl jets
- Optional removable apron
- Two air controls
- Color-Match trim, metal upgrades available (Consult Price Book for specific colors)
- Available in White and Standard Colors (Consult Price Book for specific colors)
- Outstanding protection - Mansfield® Limited One Year Acrylic Warranty

Model No.	Description	Approx.Wt.
6024	42" x 60" x 20-1/4" Rectangular whirlpool. Specify color and options when ordering.	108 lbs. (49 kg)
6524	42" x 60" x 20-1/4" Rectangular bath. Specify color and options when ordering.	88 lbs. (40kg)
PF1325	Five foot apron	15 lbs. (6.7 kg)
SWP150	Factory installed nailing flange	2 lbs. (.9 kg)
SWAPoo	Nailing flange kit	2 lbs. (.9 kg)
SWP151	Factory installed In-Line heater	3 lbs. (1.3 kg)
PF1320	Chrome lift and turn drain kit	1 lbs. (.4 kg)
PF1321	Everbrass lift and turn drain kit	1 lbs. (.4 kg)
PF1335	Chrome trim upgrade	1 lbs. (.4 kg)
PF1336	Everbrass trim upgrade	1 lbs. (.4 kg)



For more information or to order, call 800-325-4422.
www.whirlpoolbathtubs.com

4 2 6 0

Rectangular Whirlpool or Bath

PRO-FIT®

UPGRADES

Removable Apron - 5 ft. Model

- This upgrade provides quick and easy access through removable apron to whirlpool pump and interior parts.

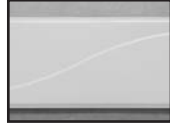

Factory Installed Nailing Flange

- Code approved, nailing flange option makes watertight installation easy and secure.



Nailing Flange Kit

- Code approved kit featuring flange material, sticky tape and instructions.
- Makes watertight installation easy and secure.



Factory Installed In-line Heater

- A reliable, heating control upgrade maintains water temperature at desired level and operates when flow of water is detected in the system. Features a standard plug for easy electrical connection (GFCI: 120V, 20 amp dedicated circuit required to power this heater).



Lift & Turn Drain Kit Chrome and Everbrass (PVD)

- The lift and turn drain kit provides simple and easy draining of the bathtub.



Trim Upgrade

- This option allows an upgrade to Chrome or Everbrass (PVD) trim including jets, intake, control and air control(s).

TECHNICAL INFORMATION

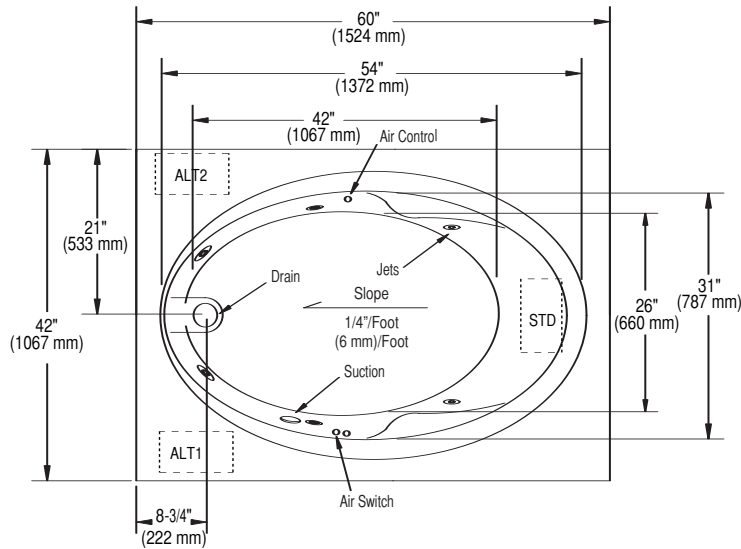

Pump locations are shown for clarity. STD-standard pump location. ALT1 and ALT2-alternate pump locations are optional.

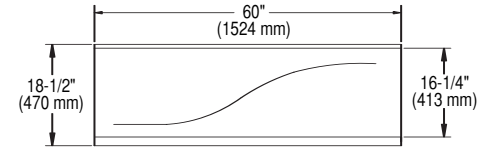

Optional Removable Apron

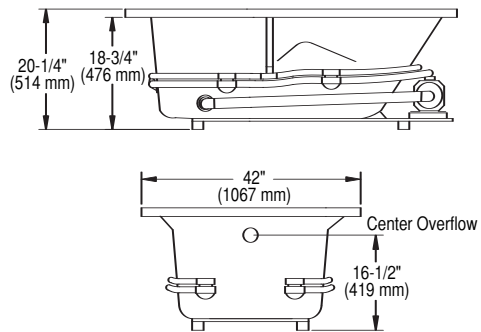

Note: If a factory installed nailing flange is added to a unit, add 1/8" to each side flanged.

Note: Measurements may vary 1/4" (6.4 mm ±)

SPECIFICATIONS

Dimensions	42" x 60" x 20-1/4"
Material	Acrylic, fiberglass reinforced
Construction	Self-contained, pre-plumbed whirlpool bath
Pump Motor	1-1/4 HP, 1 phase, 120 volt, 60 HZ, 5.9 AMP,
Electrical Requirements	120 volt, 20 AMP, GFCI

Number of Jets	Six
Air Volume Control	Two
Water Capacity	55 gal. max., 42 gal. min. (209 liters/160 liters)
Floor Loading	47 lbs./sq. ft. (229 kg/m ²)
Shipping Weight	148 lbs. (67 kg)
Warranty	Limited One Year



These dimensions are nominal and are subject to change without notice. When tested for compliance to the requirement of ANSI A112.19.7M and A112.19.8M for "Whirlpool Bath Appliances" and ANSI Z124 for "Plastic Bathtub Units" the tested units are found to comply and are acceptable for listing under the Terralab Engineers, Inc. follow-up service. Listed Number 15197. Certified for permanent electrical supply connection only.