



Model 6124
Shown in
White with
EverBrass (PVD) trim

FEATURES

- 42" x 59-3/4" x 21-1/4" Rectangular whirlpool
- Simple air-switch operation
- 1-1/4 HP single-speed pump
- Six powerful Ultra-Swirl jets
- Two air controls
- Integral apron and tile flange
- Optional removable long access panel on apron
- Color-Match trim, metal upgrades available (Consult Price Book for specific colors)
- Available in White and Standard Colors (Consult Price Book for specific colors)
- Outstanding protection - Mansfield® Limited One Year Acrylic Warranty

Model No.	Description	Approx.Wt.
6124	42" x 59-3/4" x 21-1/4" Lefthand rectangular whirlpool TFS	128 lbs. (58 kg)
6125	42" x 59-3/4" x 21-1/4" Righthand rectangular whirlpool TFS Specify color and options when ordering.	
6624	42" x 59-3/4" x 21-1/4" Lefthand rectangular bath TFS	108 lbs. (49 kg)
6625	42" x 59-3/4" x 21-1/4" Righthand rectangular bath TFS Specify color and options when ordering.	
PF1330	Access panel	3 lbs. (1.3 kg)
SWP151	Factory installed In-Line heater	3 lbs. (1.3 kg)
PF1320	Chrome lift and turn drain kit	1 lbs. (.4 kg)
PF1321	Everbrass lift and turn drain kit	1 lbs. (.4 kg)
PF1335	Chrome trim upgrade	1 lbs. (.4 kg)
PF1336	Everbrass trim upgrade	1 lbs. (.4 kg)



For more information or to order, call 800-325-4422.
www.whirlpoolbathtubs.com

4260 TFS

Rectangular Whirlpool or Bath

PRO-FIT®

UPGRADES

Removable Access Panel - 5 ft. Model

- This panel makes it a simple step to access the pump and other areas as required. Access panels available on TFS right and left hand models.



Lift & Turn Drain Kit Chrome and Everbrass (PVD)

- The lift and turn drain kit provides simple and easy draining of the bathtub.



Factory Installed In-line Heater

- A reliable, heating control upgrade maintains water temperature at desired level and operates when flow of water is detected in the system. Features a standard plug for easy electrical connection (GFCI: 120V, 20 amp dedicated circuit required to power this heater).



Trim Upgrade

- This option allows an upgrade to Chrome or Everbrass (PVD) trim including jets, intake, control and air control(s).

TECHNICAL INFORMATION

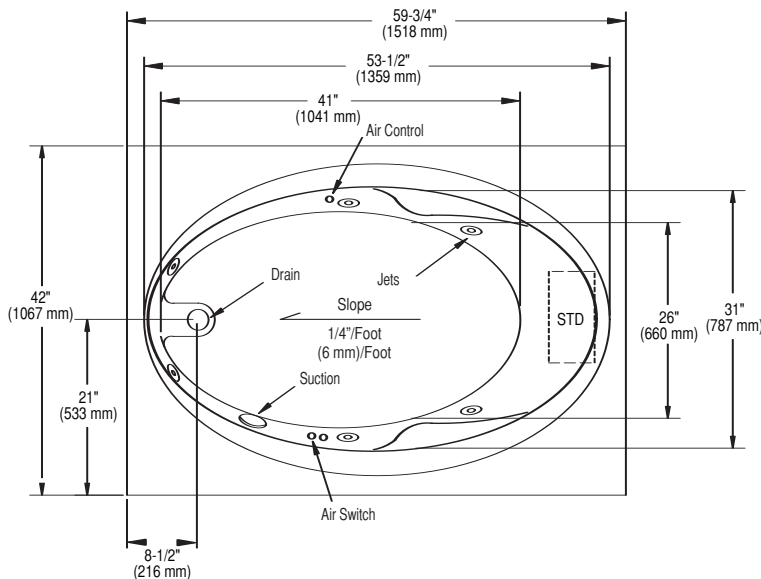

Units available with optional removable access panel for access to pump/motor and plumbing on whirlpool baths. Specify RH or LH drain when ordering.

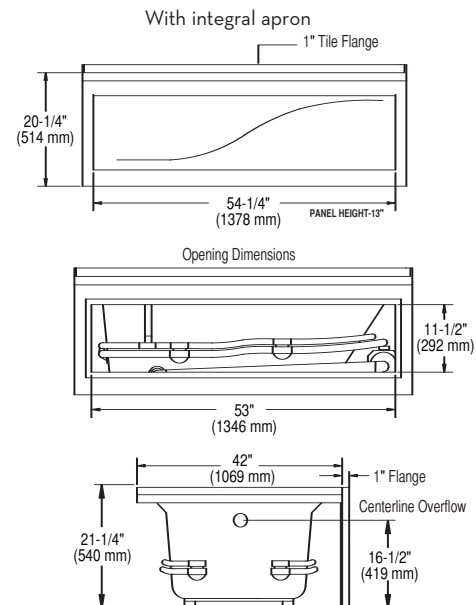

Note: Due to integral tile flange, a nailing flange is not available on this unit.

Note: Measurements may vary 1/4" (6.4 mm ±)

SPECIFICATIONS

Dimensions	59-3/4" x 42" x 21-1/4"	Number of Jets	Six
Material	Acrylic, fiberglass reinforced	Air Volume Control	Two
Construction	Self-contained, pre-plumbed whirlpool bath	Water Capacity	55 gal. max., 42 gal. min. (209liters/160 liters)
Pump Motor	1-1/4 HP, 1 phase, 120 volt, 60 HZ, 5.9 AMP,	Floor Loading	47 lbs./sq. ft. (229 kg/m ²)
Electrical Requirements	120 volt, 20 AMP, GFCI	Shipping Weight	168 lbs. (76 kg)
		Warranty	Limited One Year

These dimensions are nominal and are subject to change without notice.

When tested for compliance to the requirement of ANSI A112.19.7M and A112.19.8M for "Whirlpool Bath Appliances" and ANSI Z124 for "Plastic Bathtub Units" the tested units are found to comply and are acceptable for listing under the Terralab Engineers, Inc. follow-up service. Listed Number 15197.

Certified for permanent electrical supply connection only.

Mansfield®
performance for a lifetime™