



Model 5053
Shown in White with
Brushed Nickel Trim

FEATURES

- 32" x 59-1/2" x 21-1/2" Rectangular Whirlpool
- Deep bathing well
- Hydro-V™ back jet system: Six jets massage the shoulder blades, upper and middle back muscles and the bottom two spinning jets for your lower back
- Exclusive handles and pillows
- Swirl-way® DryJets are adjustable in both direction and flow creating a broad, circular pattern of water and warm air for a deep venturi therapeutic massage
- Powerful 2 HP pump system creates an invigorating whirlpool action
- Dual air controls for the ultimate jet power control
- Trim finish in your choice of Color-Match, Chrome, Everbrass (PVD) and Brushed Nickel
- Outstanding Protection - Mansfield® Limited Ten Year Warranty
- Available in White, Standard, Premium and Designer Colors (Consult Price Book for specific colors)

The Camden features a deep bathing well and the Hydro-V™ back jet system. A twelve jet system gives the bather a full featured whirlpool by using every inch for bathing space. Swirl-way's® exclusive ergonomic handles and pillow complement your own personal oasis.

Model No.	Description	Approx.Wt.
5053	32" x 59-1/2" x 21-1/2" Rectangular whirlpool. Specify color and options when ordering.	85 lbs. (38 kg)
5553	32" x 59-1/2" x 21-1/2" Rectangular bath. Specify color and options when ordering.	65 lbs. (29 kg)
5053LUX	Luxury package	
5053BAS	Basic package	



For more information or to order, call 800-325-4422.
www.whirlpoolbathtubs.com

CAMDEN

Rectangular Whirlpool or Bath



FEATURES & UPGRADES

Basic Package

- SimpleTouch™ 3 button control
- 2 HP single speed pump
- Exclusive custom grab bars
- Pillow
- Color-Match trim



Basic Options

- Infusion™ 2 Chromatherapy system
- 1500 watt in-line water heater
- Metal trim upgrade
- Cable drain in CM, CH, EB & BN
- Nailing flange kit
- Factory installed nailing flange
- Removable 5 foot apron

Luxury Package

- SensaSelect™ 5 button control
- 2 HP 10-speed pump
- Remote control
- Exclusive custom grab bars
- Pillow
- Infusion™ 2 Chromatherapy system
- In-Line heater
- Metal trim upgrade

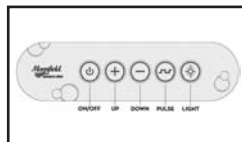

TECHNICAL INFORMATION

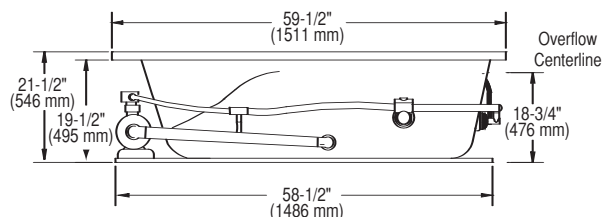
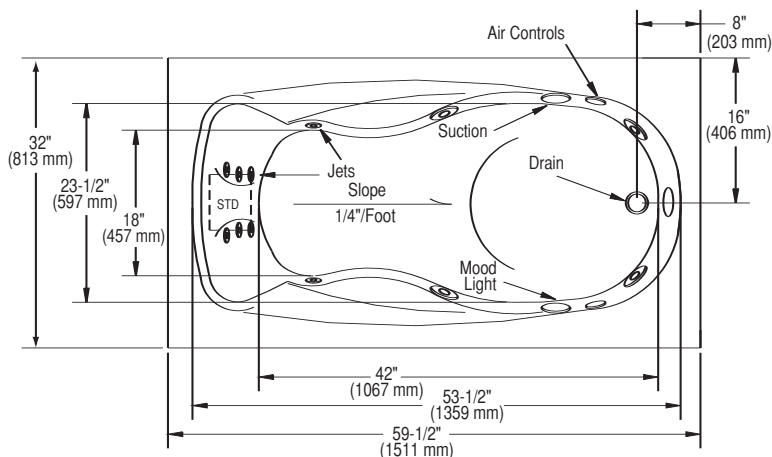

No apron available on this model

STD-standard pump location is as shown.

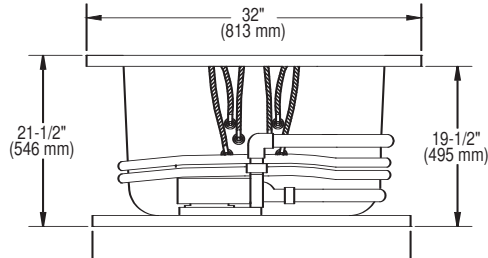

Note: Install this product according to the installation guide. Fixture dimensions are nominal and conform to tolerances in ASME Standard A112.19.2

SPECIFICATIONS

Dimensions	32" x 59-1/2" x 21-1/2"
Material	Acrylic, fiberglass reinforced
Construction	Self-contained, pre-plumbed whirlpool bath with heat-bent rigid PVC pipe, mounted on a pre-leveled thermoformed, drip pan base
Pump Motor	2 HP, Ten speed, 120 volt, 60 HZ, 13.5 AMP
Electrical Requirements	Lux.-Sen.: Two separate 120 volt, 20 AMP, GFCI protected circuits Basic: One separate, 120 volt, 20 AMP, GFCI outlet

Number of Jets	Twelve
Air Volume Control	Two
Water Capacity	52 gal. max., 42 gal. min. (201 liters/159 liters)
Floor Loading	47 lbs./sq. ft. (229 kg/m ²)
Shipping Weight	130 lbs. (59 kg)
Warranty	Limited Ten Year

These dimensions are nominal and are subject to change without notice. When tested for compliance to the requirement of ANSI A112.19.7M and A112.19.8M for "Whirlpool Bath Appliances" and ANSI Z124 for "Plastic Bathtub Units" the tested units are found to comply and are acceptable for listing under the Terralab Engineers, Inc. follow-up service. Listed Number 15197. Certified for permanent electrical supply connection only.

