

SPECIFICATIONS

EL530, EL535 & EL635

Whirlpool & Soaking Bath

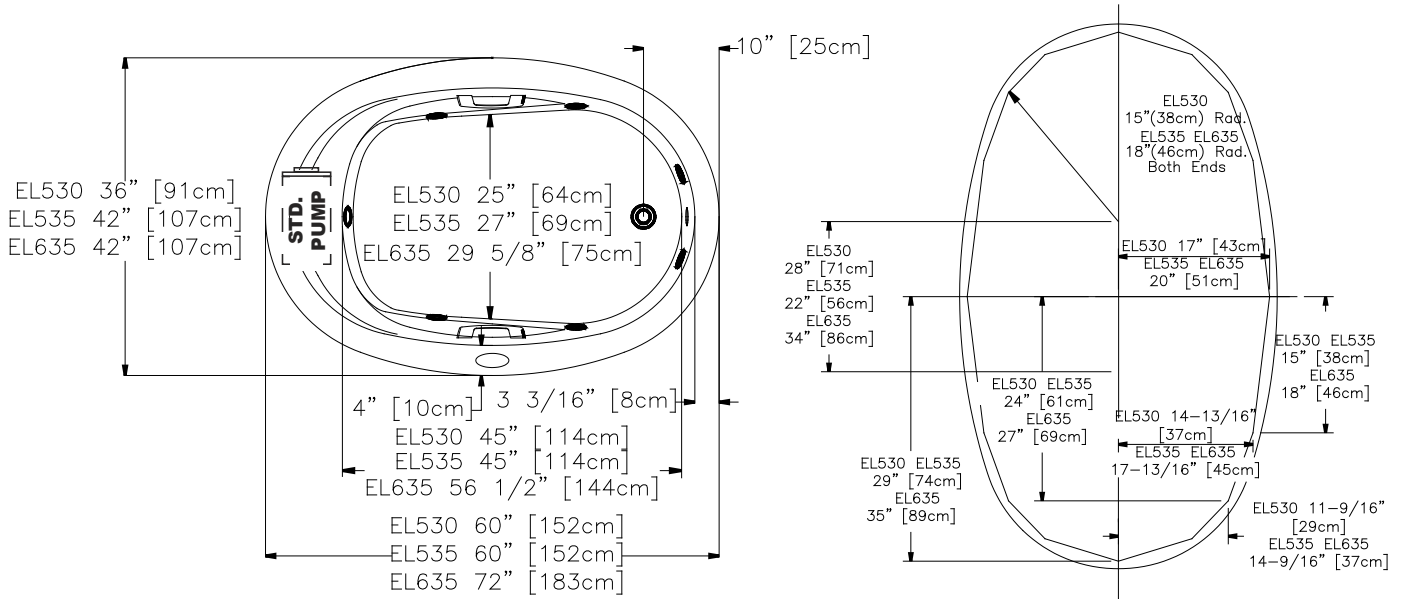

Drop In Hole Size

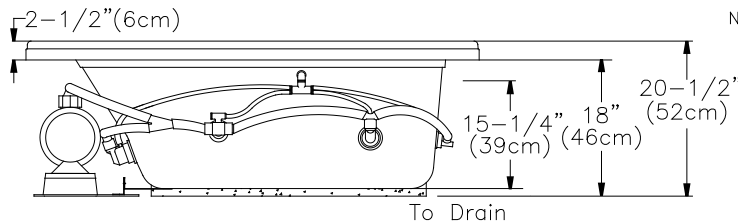

Note: The pump extends approx. 1" past the end radius of the bath. This requires angling the bath into the drop in hole.
Dimensional Tolerances: ±1/4"



Patents recieved or pending.

Note: Dimensional Tolerances: ±1/4"

	EL530	EL535	EL635
Drop-in-Hole Size:	See Diagram	See Diagram	See Diagram
Operating Capacity:	36 gal	49 gal	52 gal
Overflow Capacity:	57 lbs	77 gal	80 gal
Floor Loading / sq.ft.:	31.3 lbs	48.2 lbs	46.3 lbs
Cartoned Wt: Whirlpool	101 lbs	115 lbs	125 lbs
Cartoned Wt: Soaker	69 lbs	76 lbs	102 lbs
Cube:	31.3 cu. ft.	36.2 cu. ft.	43.2 cu. ft.

Construction: Fiberglass reinforced acrylic bath with Level Form™ full-support base

We provide products listed with Underwriters Laboratories, Inc. (UL), International Association of Plumbing and Mechanical Officials (IAPMO), and Canadian Underwriters Laboratory (CUL). Consult factory with your listing requirements.

Standard	 <p>1 1/2 hp, 1 speed pump, touch control with low water level sensor, and a 20-minute timer. Light indicates when pump is on. Requires one (1) 120V 20A dedicated GFCI-protected circuits.</p>
Signature	 <p>1 1/2 hp, 3 speed pump, digital control with low water level sensor, water temperature sensor, 20-minute timer, automatic 1.5 kW heater, and a front access LED moodlight. Shows water temperature and time remaining. Floating Universal Remote Control operates all bath and light functions plus TV, VCR, CD, etc. Requires two (2) 120V 20A dedicated GFCI-protected circuits.</p>